

## Technical Specification

**Material:** 304 Stainless Steel

**Finish:** Bead Blasted

**Spurge Water Inlet:** 1/2" BSP Hose Tail / Internal Thread

**Dosed Water Inlet:** 1/2" BSP Hose Tail / Internal Thread

**Drainage:** 2" BSP Hose Tail / Internal Thread

**Pressure:** 5 Bar

**Temperature:** 5 - 45°C Max

**Flow:** 2.4 Litres/min

**Control:** Automatic activation / 5m remote start/stop.

**Electrical Supply:** 240V Single Phase 1.2kW

- 2m flying lead with commando plug

## WSW10 - Walkthrough Sole Washer

- Easy access to brushes for removal the use of hand tools
- Castors for easy manoeuvrability
- Easy access to brush motors and s
- Low atomising spray nozzles to mir
- Removeable sump basket
- Hose tails used for simple plumbing
- Adjustable run times for brushes &
- Lockable storage cabinets and elec
- Photoelectric sensors for automatic
- Economical water consumption
- Low voltage switchgear
- Safety torque restricted motors
- CE Approved

## Optional Extra

- Wall mounted remote panel
- Chemical Dosing Pump
- Site installation

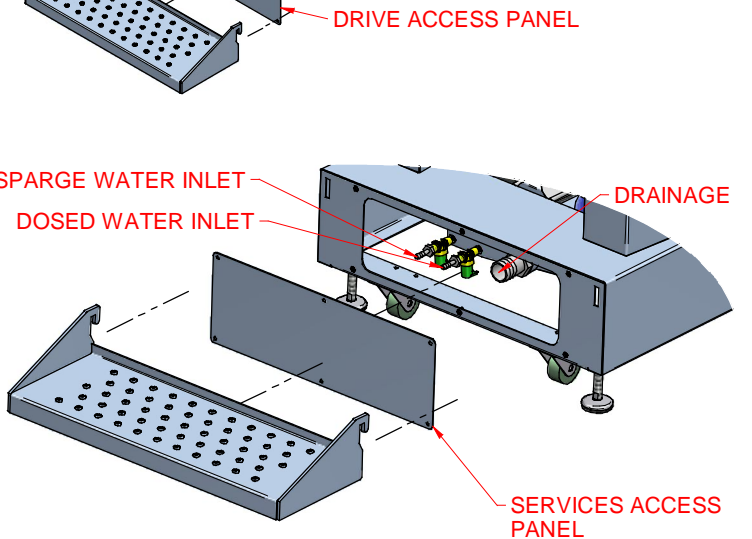
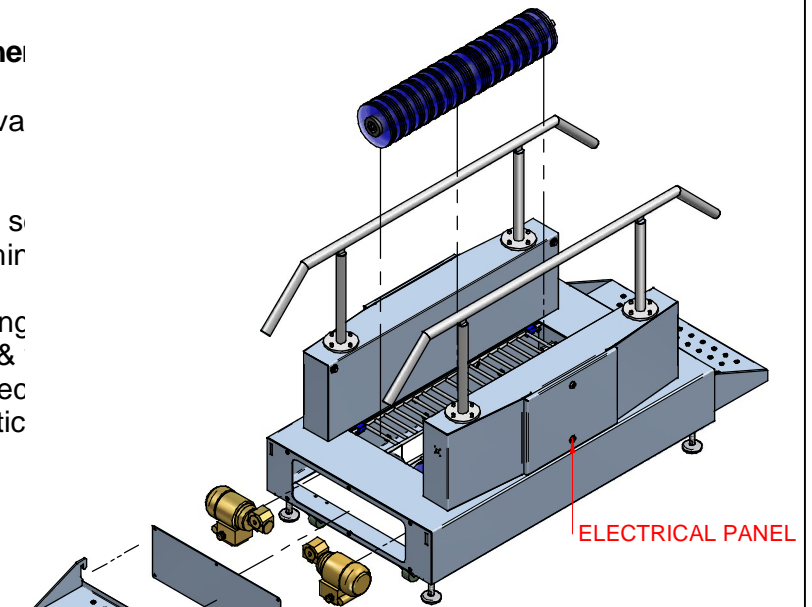
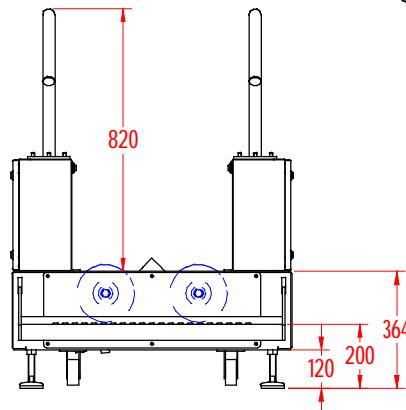
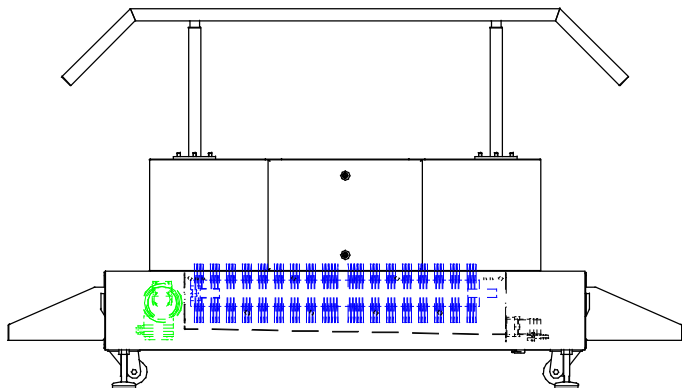
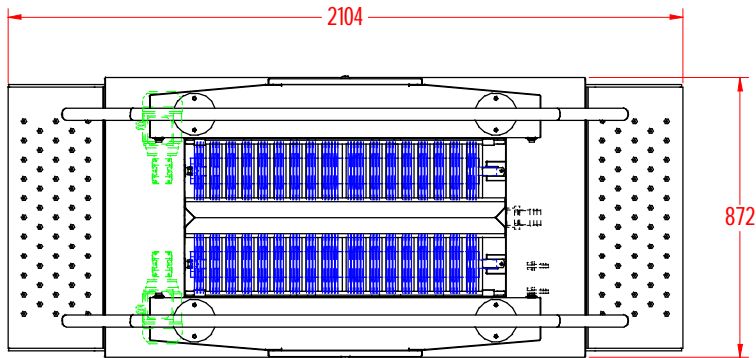

		PRODUCT	Walkthrough Sole Washer
		MODEL NO:	WSW10
<small>THIS DRAWING AND THE CONTENTS THEREOF ARE CONFIDENTIAL AND THE PROPERTY OF PROTECH FOOD SYSTEMS LTD. NEITHER THE DRAWING NOR ITS CONTENTS MAY BE COPIED OR OTHERWISE REPRODUCED OR DISCLOSED TO ANY THIRD PARTY WITHOUT THE WRITTEN CONSENT OF PROTECH FOOD SYSTEMS LTD.</small>		MATERIAL	304 Stainless Steel
3rd ANGLE PROJECTION	SCALE	FINISH	Bead Blasted
	NTS		PAGE NO. 1 of 1